



COMPOSITE ROOF SYSTEM WITH LOC-SEAM

1. PRODUCT NAME

Composite Roof System for roof applications.

2. MANUFACTURER

ARCHITECTURAL METAL SYSTEMS

1150 State Docks Road
Eufaula, Alabama 36027
Phone: (334) 688-2650

3. PRODUCT DESCRIPTION

These standing seam roof panels offer a flat profile, with minor striations and optional pencil ribs, for an attractive appearance on higher pitched roofs. Loc Seam panels are seamed electrically and Loc-Seam 360 panels have full 360 degree rolled seams formed with an electrical seaming machine.

Basic Use: A roof covering system for new or retrofit construction. A specially designed roof system combines American's Loc Seam roof panel with a layer of rigid insulation board and a Multi-rib liner panel giving the interior a finished look with excellent insulating properties. Thermax rigid insulation is applied between the interior and exterior panels. A compressible blanket insulation (unfaced) 1" thickness before compression is located between the exterior panel and the rigid insulation (while optional, this insulation is highly recommended to minimize panel rumbling in high winds). An optional 3 mil (or equivalent) vinyl vapor barrier may be used between the liner panel and the rigid insulation.

Materials: Loc Seam panels are 24 and 22 gage 50,000 psi either G90 zinc-coated (galvanized) or AZ50 aluminum-zinc alloy-coated steel. Pre-painted panels have Architectural Metal Systems' Marquis Series Premium (Kynar 500®) Finish.

The Multi-rib liner has 3/4" ribs with major corrugations spaced on 6" centers. They offer 36" width coverage. Rigid insulation is Thermax® by Celotex Corporation, Types TF600, TF604, TF610 or Thermax Plus with a maximum thickness of 5-1/2" in a double layer or 4-1/2" in a single layer.

The Loc Seam clip is a two part assembly. The tab portions are a nominal 2-3/8" in height and 3" in width, die formed 24 gage aluminum coated steel. The bases are die formed 18 gage zinc-coated (galvanized) steel. Expansion capability is 1-1/4".

Bearing plates for the Loc Seam panel clips are 20 gage zinc-coated (galvanized) or aluminum-zinc alloy-coated steel.

Loc Seam panel sidelaps have factory applied mastic, SikaLastomer-511 or equal. Its composition is 85% solids by weight. Service temperature range is -60°F to + 220°F.

Endlaps, roof flashing laps, ridges and eave closures are sealed with tape mastic, Sika Sika-Tape TC-95 or equal. The material is non-staining, non-corrosive, non-toxic and non-volatile. Composition is 100% solid ethylene propylene copolymer tape. Service temperature is -60°F to +212°F. Eaves, endlaps, ridge and eave closures are sealed with non-skinning butyl caulk, SikaLastomer-511 or equal. Its composition is 85% solids by

weight. Service temperature range is -60°F to + 220°F. All gutter and downspout joints, and roof accessories are sealed with polyurethane caulk, Sika SikaFlex 219LM or equal. It meets or exceeds Federal Specification TT-S-00230C, Type II, Class A.

All fasteners for panel to secondary framing and panel to panel will be one of the following EPDM washer head screws.

A. Premium roof fasteners shall be No. 14 x 1" self-drilling carbon steel screws with a molded zinc alloy or capped stainless steel cupped hex washer head. Premium roof fasteners will be on all warranted roofs and all pre-finished roofs.

B. Standard roof fasteners shall be No. 14 x 1" self-drilling carbon steel screws with an integral hex washer head. Standard roof fasteners shall have a corrosive resistant coating over zinc plating. Standard roof fasteners shall be on unwarranted aluminum-zinc, alloy-coated roofs only. Loc Seam panel clips are attached to the purlins with self-drilling carbon steel screws No. 12 hex head, cadmium or zinc plated. The screw length is determined by the thickness of the rigid insulation. Multi-rib panels are attached to the secondary framing members by self-drilling carbon steel screws, No. 12 x 1-1/4" hex head, cadmium or zinc plated. Panel sidelaps are stitched with self-drilling carbon steel screws, No. 14 x 7/8" cadmium or zinc plated.

4. TECHNICAL DATA

The Loc Seam 360 panel has received a Class 90 Wind Uplift rating by Underwriters Laboratories when tested in accordance with test procedure UL 580. The Loc Seam 360 roof panel has been Factory Mutual approved and tested in accordance with Wind Uplift ASTM E1592 and CECS 07416. This panel has also been tested in accordance with Air Infiltration, ASTM E1680 and Water Penetration, ASTM E1646. This panel has been approved for SREF (SSTD-97) Impact Testing. This panel has received a Class A fire rating when tested in accordance with test procedure ASTM E108.

The Loc Seam panel has received a Class 90 Wind Uplift rating by Underwriters Laboratories when tested in accordance with test procedure UL 580. The Loc Seam roof panel has been tested in accordance with CECS 07416. This panel has also been tested in accordance with Air Infiltration, ASTM E1680, ASTM E283 and Water Penetration, ASTM E1646, ASTM E331. This panel has received a Class A fire rating when tested in accordance with test procedure ASTM E108.

5. INSTALLATION

Installation should be performed in accordance with Architectural Metal Systems' manuals and building erection drawings, and should be by a qualified installer using proper tools and equipment. Systems are installed by Architectural Metal Systems Preferred Roofing Contractors.

continued...on back

6. AVAILABILITY

For availability, contact:

Architectural Metal Systems
1150 State Docks Road
Eufaula, Alabama 36027
Phone (334) 688-2650

7. WARRANTY

Thirty-five year paint finish and twenty year weathertightness warranties are available.

8. MAINTENANCE

Only normal routine maintenance is required over the life of the panels.

9. TECHNICAL SERVICES

For information, contact:
Architectural Metal Systems
1150 State Docks Road
Eufaula, Alabama 36027
Phone (334) 688-2650

10. PRODUCT NOTES

A certain amount of waviness called "oilcanning" may exist in this panel. Minor waviness of the panel is not sufficient cause for rejection, because oilcanning does not affect the structural integrity of the panel.

Architectural Metal Systems reserves the right to revise all standard specifications and information. Architectural Metal Systems regularly updates its published "Standard Specifications" on the AMS web site, www.ametalsystems.com, which supercede and replace any previously published standard specifications of Architectural Metal Systems.

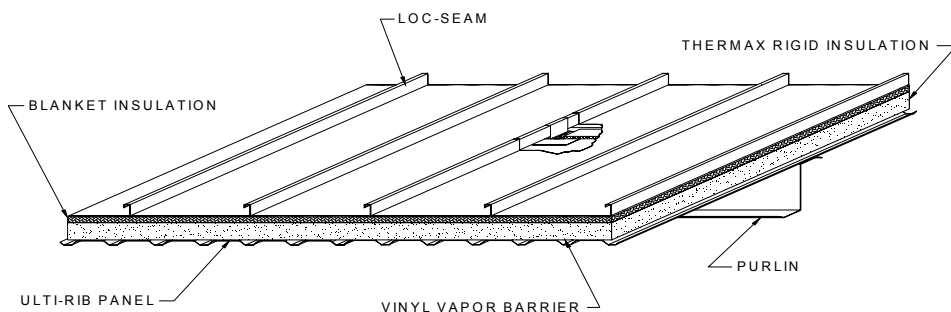

System "R" Values

Thermax	Winter	Summer
1"	9.8	10.5
1 1/2"	13.8	14.1
2"	17.8	17.7
2 1/2"	21.8	21.3
3"	25.8	24.9
4"	33.8	32.1

Engineering Properties of AMS' 16" Loc-Seam / Loc-Seam 360 Panel								
Designated Gage Of Steel	Base Metal Thickness (Inches)	Total Thickness (Inches)	Panel Weight (lbs./ft. ²)	Top		Bottom		Fy/1.67 (ksi)
				In Compression	In Compression	In Compression	In Compression	
				Ix (In ⁴ /ft.)	Sx (In ³ /ft.)	Ix (In ⁴ /ft.)	Sx (In ³ /ft.)	
24 Gage	0.0225	0.0230	1.29	0.152	0.079	0.071	0.060	30
22 Gage	0.0300	0.0301	1.69	0.213	0.127	0.106	0.092	30
Designated Gage Of Steel	Number of Spans	Maximum Total Uniform Load in PSF						
		L = 2'-6"	3'-0"	3'-6"	4'-0"	4'-6"	5'-0"	
24 Gage	1	254	177	130	99	78	64	
	2	192	133	98	75	59	48	
	3	240	167	122	94	74	60	
	4	224	156	114	88	69	56	
22 Gage	1	405	281	207	158	125	101	
	2	295	205	150	115	91	74	
	3	368	256	188	144	114	92	
	4	344	239	175	134	106	86	

1. Section properties have been calculated in accordance with the *AISI specifications for the Design of Cold-Formed Steel Structural Members, 1996 Edition, including Supplement No. 1 (1999)*
2. Minimum yield strength of steel is 50,000 psi.
3. Steel panels are either aluminum-zinc alloy or G-90 coated. The base metal thickness shown is the minimum design thickness and was used in determining section properties.
4. Positive load is downward load applied to the top of the panel cross section as shown above.
5. The loads shown are limited by the more critical of Span/150 deflection or the allowable bending moment with no stress increase.